

# In-Line Pump DW350iL (9-350)



The DW350iL is engineered for high flow at high pressure. The pump is rated at 350lph at 40psi and maintains over 300lph at 70psi. This flat flow curve is a result of combining a high torque motor and a roller-vane pumping mechanism, High flow at high pressure is a must for turbo and supercharged applications. Plumbing is easy with the -8AN ORB inlet and outlet. The 350iL is compatible with ethanol blended fuels but is NOT compatible with methanol or diesel fuels. All DW fuel pumps are backed by a 3-yr no-fault warranty.

To ensure maximum voltage at the pump, a 12-gauge hardwire kit is strongly recommended for optimum performance (DeatschWerks part #FPHWK)

## Specifications

<b>Weight</b>	34oz (975grams)
<b>External Materials</b>	Hard Anodized Aluminum
<b>Inlet Fitting</b>	-8 AN ORB
<b>Outlet Fitting</b>	-8 AN ORB
<b>PRV Activation</b>	NA
<b>Impeller Design</b>	Roller-Vane
<b>Connector Terminal</b>	Binding Post ( M5x0.8 )
<b>Min Voltage Input</b>	8 Volts
<b>Max Voltage Input</b>	18 volts
<b>Current Draw 40psi</b>	12.0 amps (13.5v)

\* This pump does not have an internal check valve

\* Torque spec for electrical terminals is 25-30 in-lb

## Delivery Characteristics

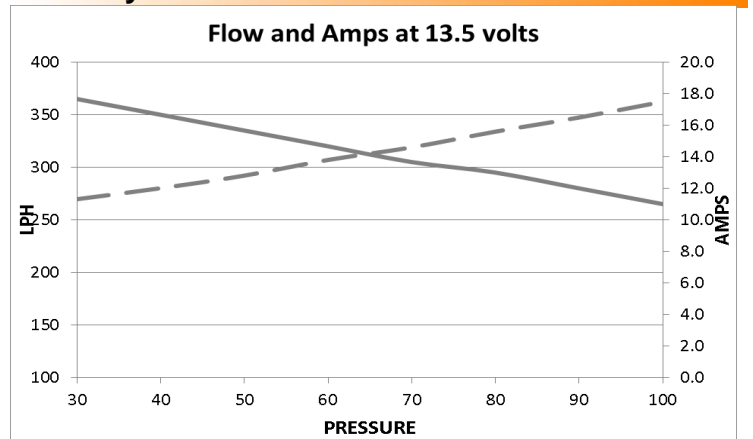

	30	40	50	60	70	80	90	100
AMP	11.3	12.0	12.8	13.8	14.6	15.6	16.5	17.5
LPH	365	350	335	320	305	295	280	265

## Dimensions

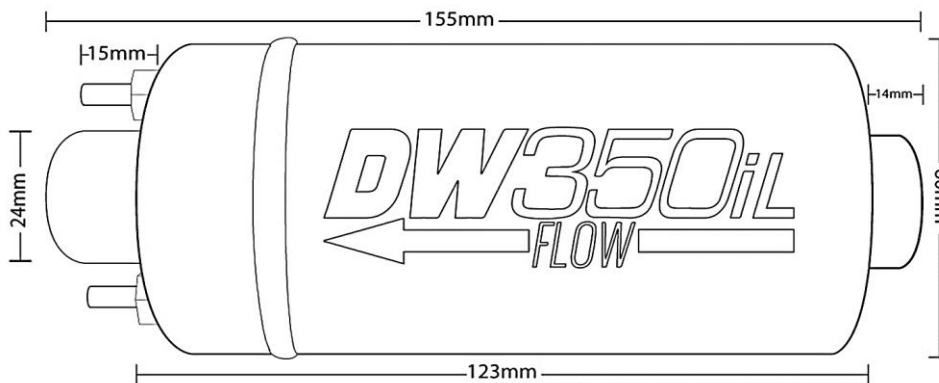

THIS PRODUCT MAY BE USED SOLELY ON VEHICLES USED IN SANCTIONED COMPETITION WHICH MAY NEVER BE USED UPON A PUBLIC ROAD OR HIGHWAY, UNLESS PERMITTED BY SPECIFIC REGULATORY EXEMPTION